

Six Point Seat Belt Installation

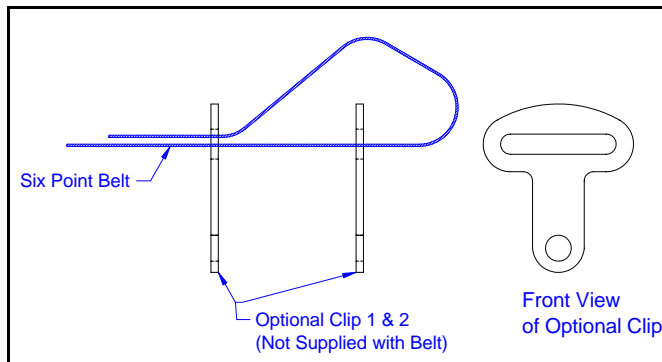

Fig. 1

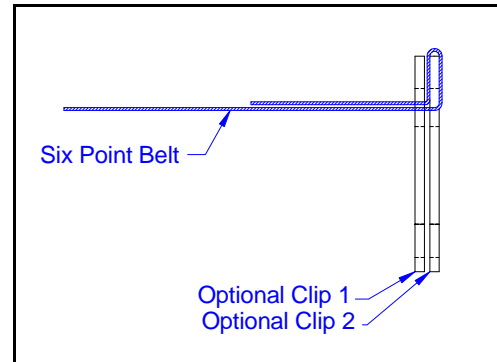

Fig. 2

Step 1: Remove the buckles and hardware that came with the six way leg straps originally. These will not be used, and are replaced by the Optional Clip depicted in Fig. 1. Run the end of the strap through the slot in the first and second Optional Clip, and then loop the strap up and over the second Optional Clip and back through the first Optional Clip in the opposite direction. See Fig. 1

Step 2: Slide The two clips together, making sure you have the correct length adjustment made for your application.

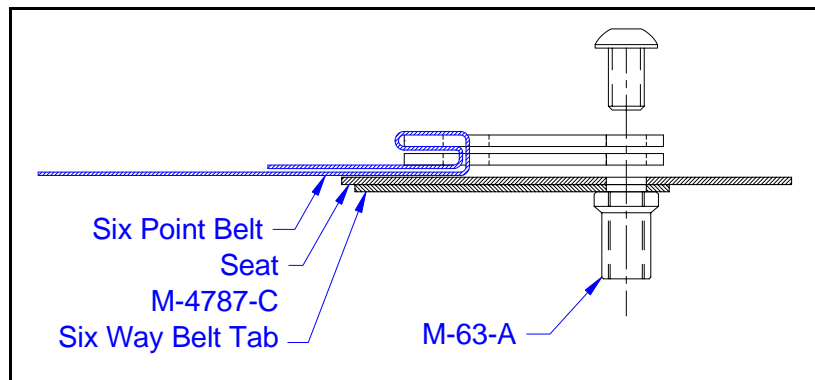

Fig. 3

Step 3: Turn Clips parallel to strap with the strap doubled under the Optional Clips and bolt to the topside of the seat. This pinches the straps into position between the seat and M-4787-C Six Way Belt Tab. See Fig. 3.