

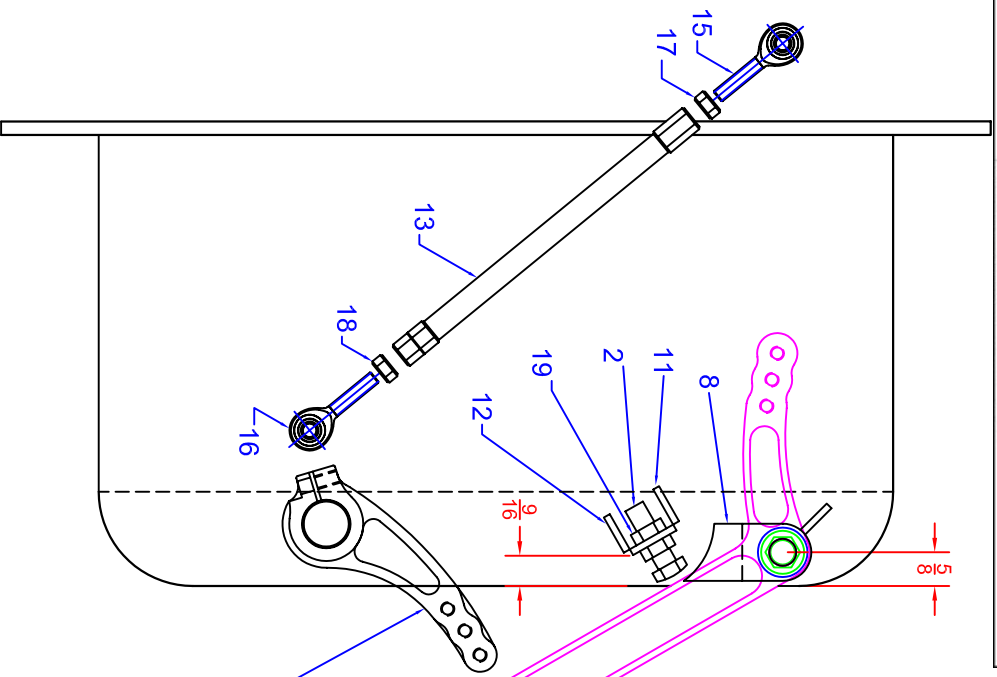

Part Number	F-905
Description	F-905 Kit Assy Instructions
Material	per BOM
Date	12/23/2004
Blank Size	MM
Drawn By	MM
Path	DRAW/Instructions/F-905 Assy Instructions.dwg
Notes	M-145 Fuel Clutch Pedal for Steel Bellhousing
Fixture No.	Inventory
Customer	Inventory
Routing	
Current Rev.	Unless Specified
Tolerance	.000 Allow +/- .003 ; .00 Allow +/- .010 Hole Diameters + .005 -.000

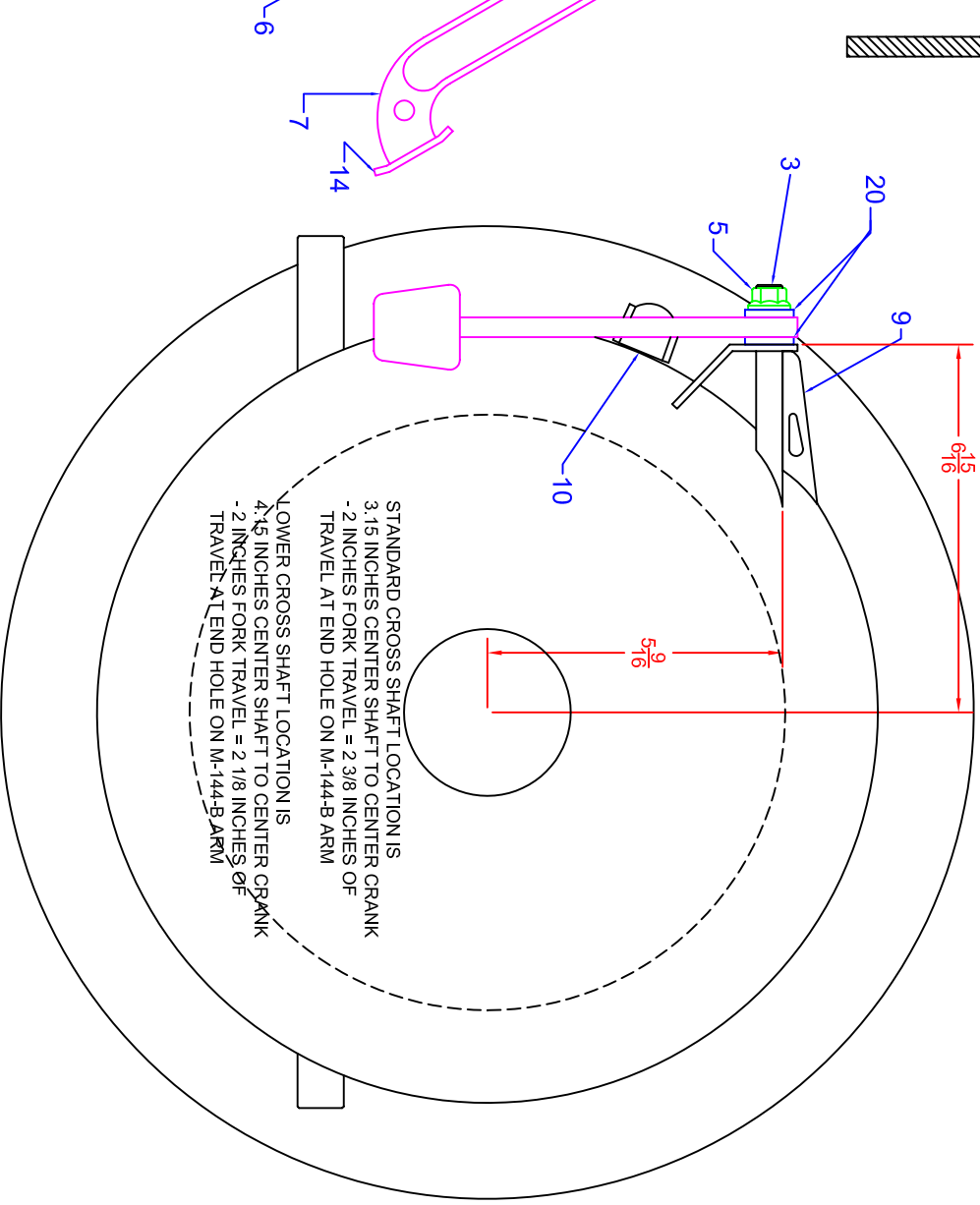

Shoulder of bolt must go all the way through M-145 Clutch pedal.

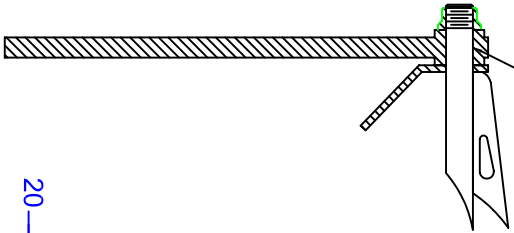

Item No.	Part No.	Description	Qty	Operation
1	BNW 416F	1/4"-28 x 1" Gr. 8 Bolt	2	Heims To Pedal & Arm
2	BNW 620F	3/8"-24 x 1 1/4" Gr. 8 Bolt	1	Stop
3	BNW 888F	1/2"-20 x 5 1/2" Gr. 8 Bolt	1	Pivot Stud
4	M-1008	10-32 x 6 Flat Head Screw	2	Pedal Pad
5	M-1038	1/2"-20 Jet Nut	1	Pivot
6	M-144-B	Crossshaft Arm	1	
7	M-145	Fuel F/C Clutch Pedal	1	
8	M-153-B	Clutch Pedal Support Tab	1	
9	M-153-C	Clutch Pedal Support Tab	1	
10	M-153-F	Clutch Pedal Gusset	1	
11	M-153-G1	Clutch Pedal Stop Tab	1	
12	M-153-G2	Stop Tab Gusset - Top	1	
13	M-153-LF	Fuel F/C Clutch Link	1	
14	M-154	Clutch Pedal Pad	1	
15	M-3014	1/4" Heim (Standard)	1	Link Heim
16	M-3001-L	1/4" Heim (Standard) Left	1	Link Heim
17	M-3041	1/4" Jam Nut	1	Link Heim
18	M-3041-L	1/4" Left Hand Jam Nut	1	Link Heim
19	M-3043	3/8" Jam Nut	2	Stop
20	AN9608	1/2" AN Flat Washer	2	